

(D) Montageanleitung

(GB) Assembly instructions

(NL) Handleiding voor de montage

(PL) Instrukcja montażu

(TR) Montaj talimatı

(RU) Инструкция по монтажу

Service • Dienstverlening • Serwis • Servis • Сервисная служба







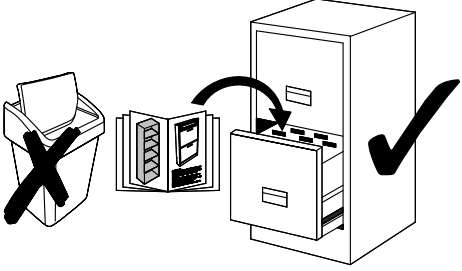
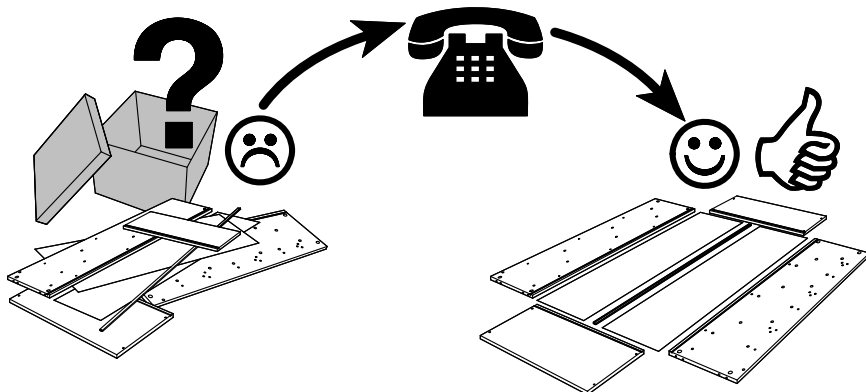

Name • Naam • Nazwa • İsim • Название

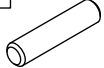
Nr. • No. • Номер

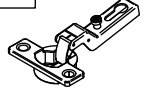
Typ • Type • Tip • Тип

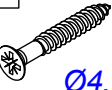

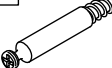



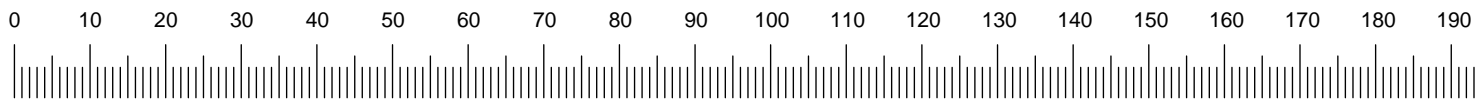
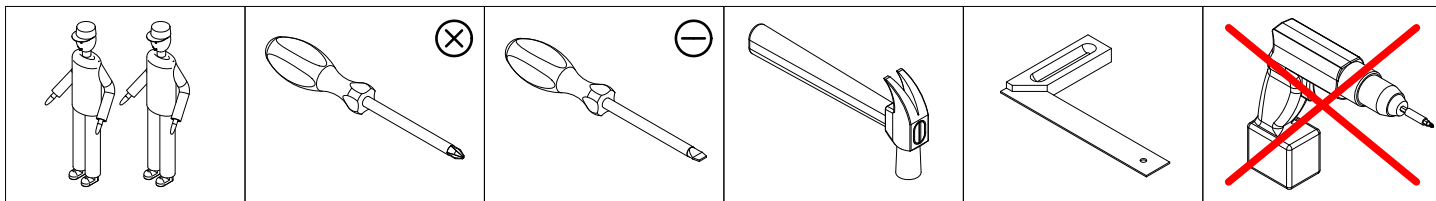

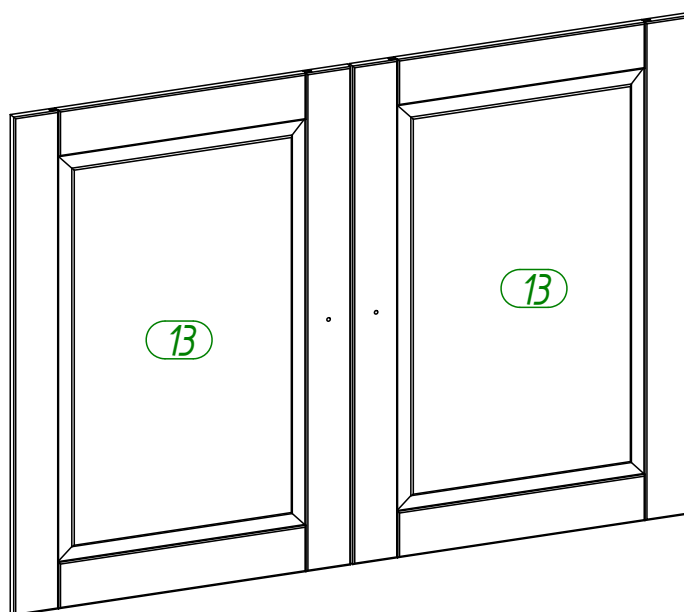
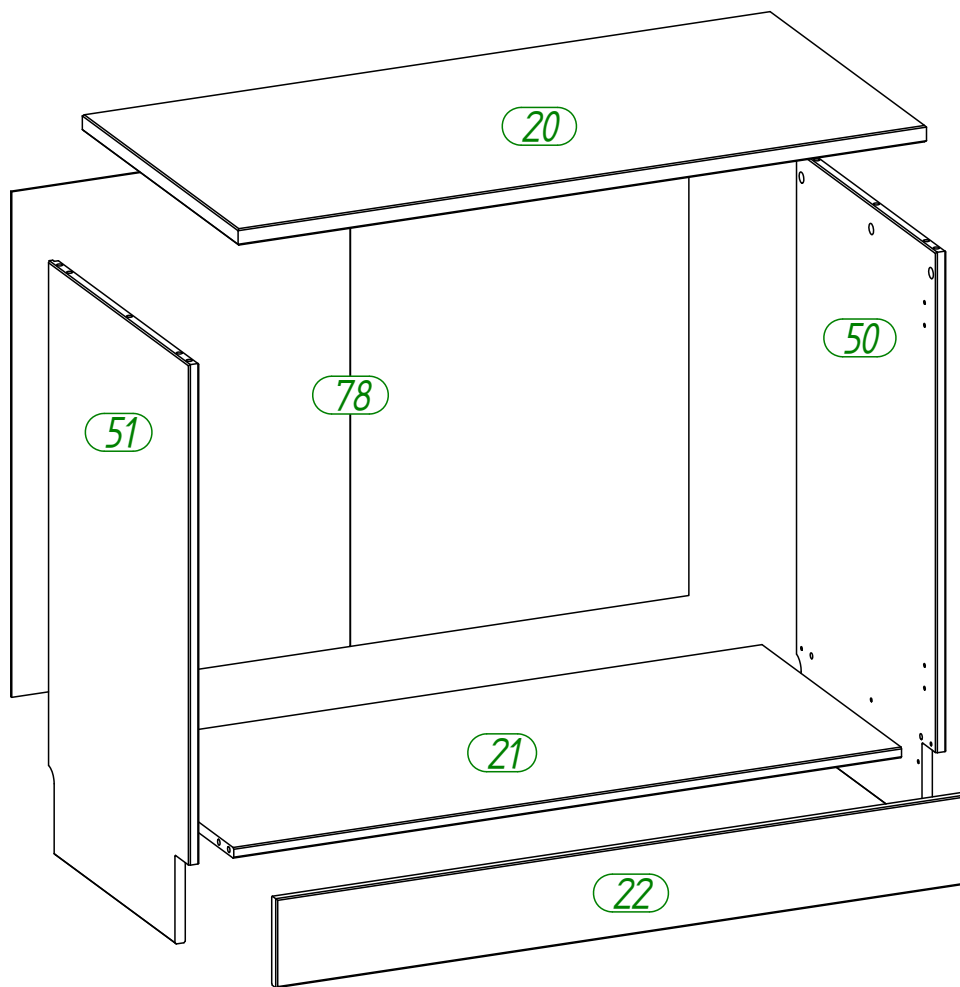
A	 8 x Ø8 x 35	D	 8 x Ø6,3 x 12	G	 4 x	H	 4 x	L	 8 x Ø3,5 x 15	O	 2 x Ø4,0 x 35
S	 12 x Ø15 x 11	Z	 4 x 20 x 20 x 16	U	 12 x L - 34	W	 50 x Ø1,2 x 20	Y	 2 x Ø34 x 29		

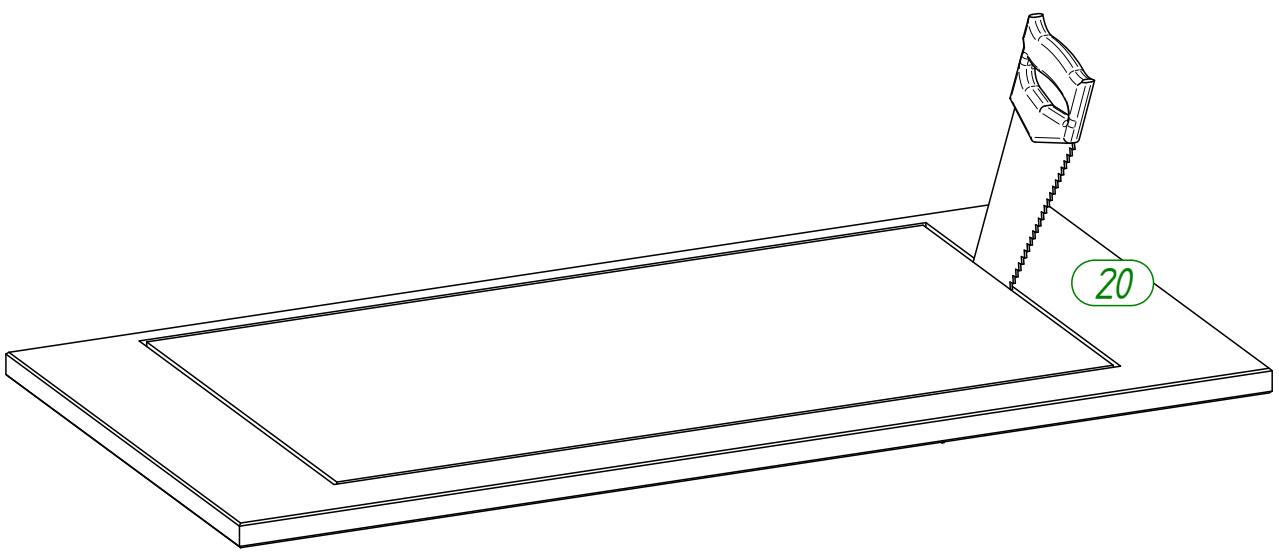
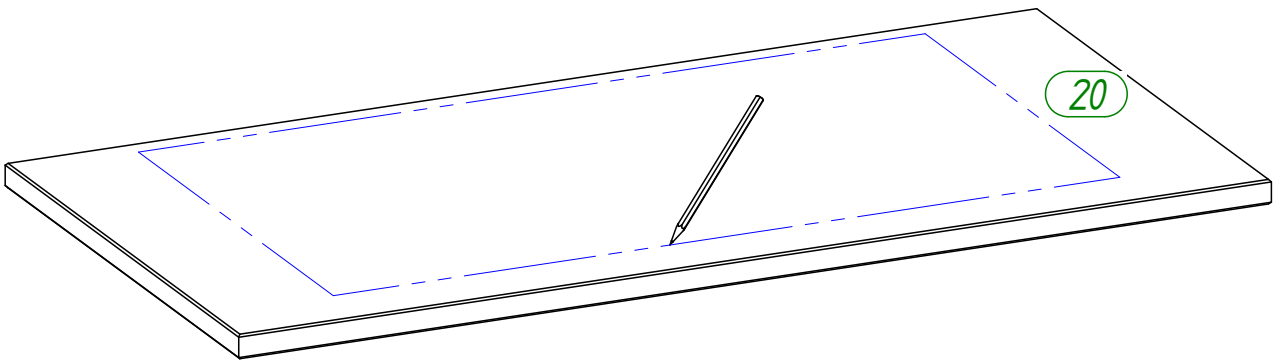
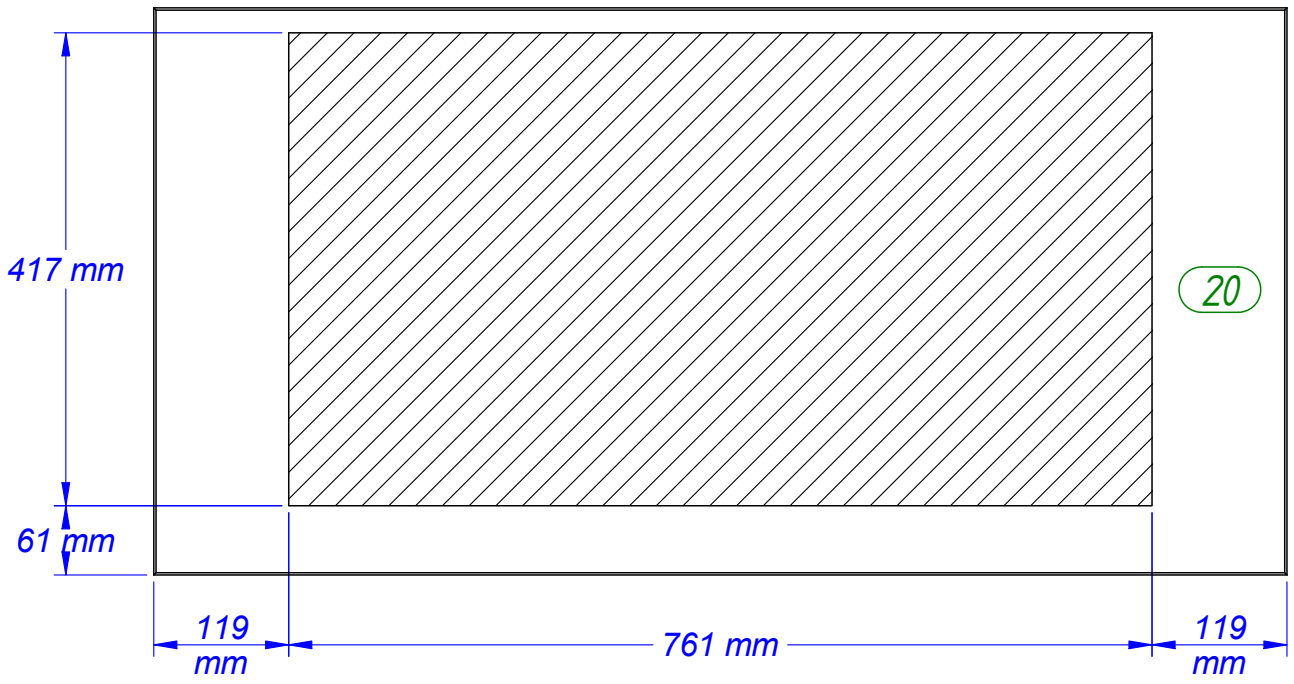





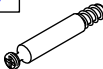

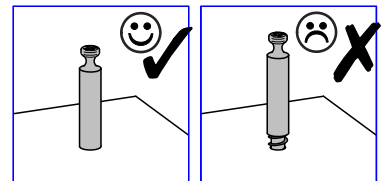
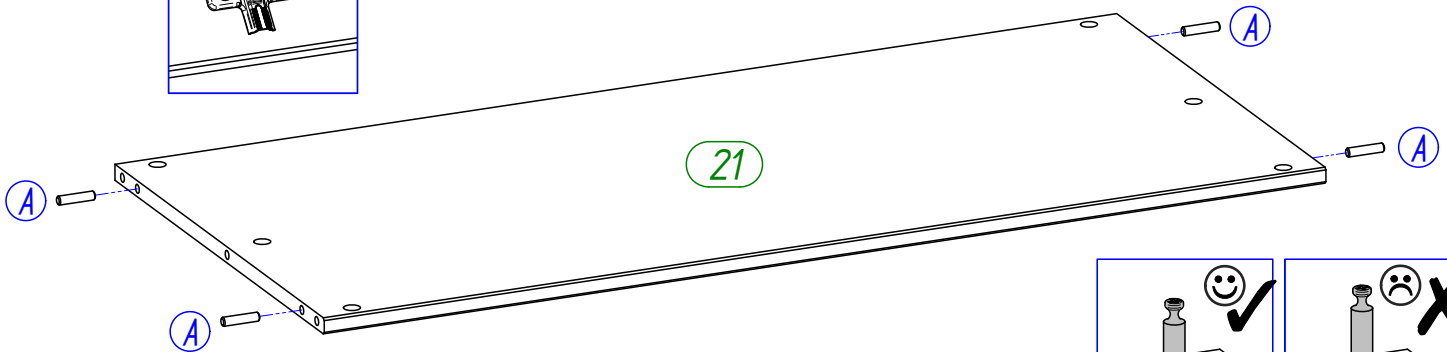
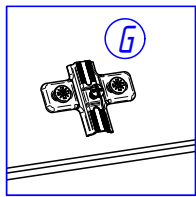
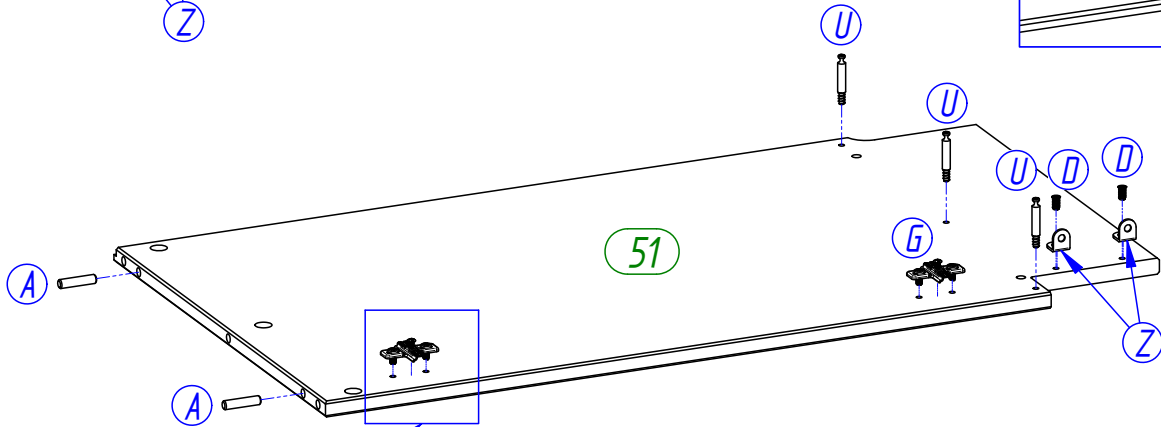
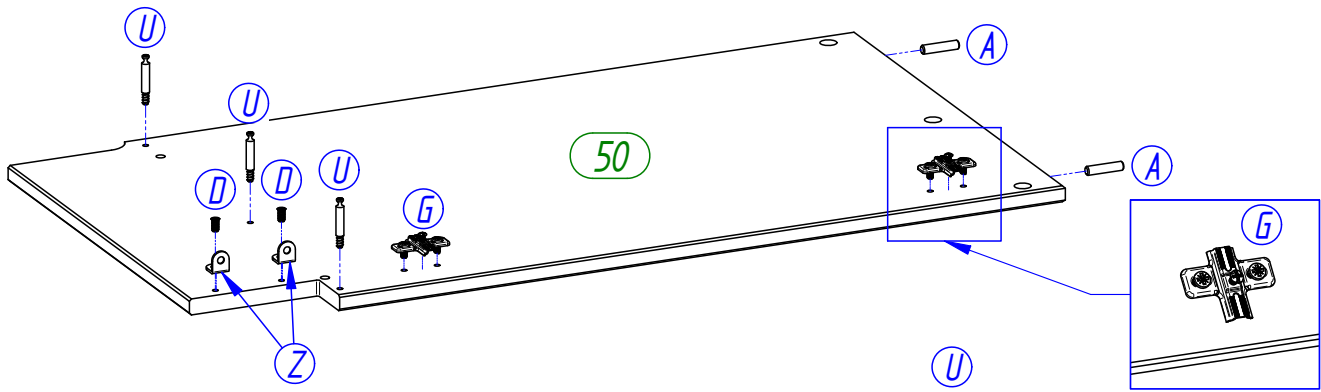

1

A	8 x	D	4 x	G	4 x	U	6 x	Z	4 x
									
	Ø8 x 35		Ø6,3 x 12				L - 34		20 x 20 x 16

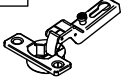

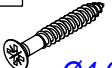
2

H	4 x	L	8 x	O	2 x	Y	2 x
							
		Ø3,5 x 15		Ø4,0 x 35		Ø34 x 29	

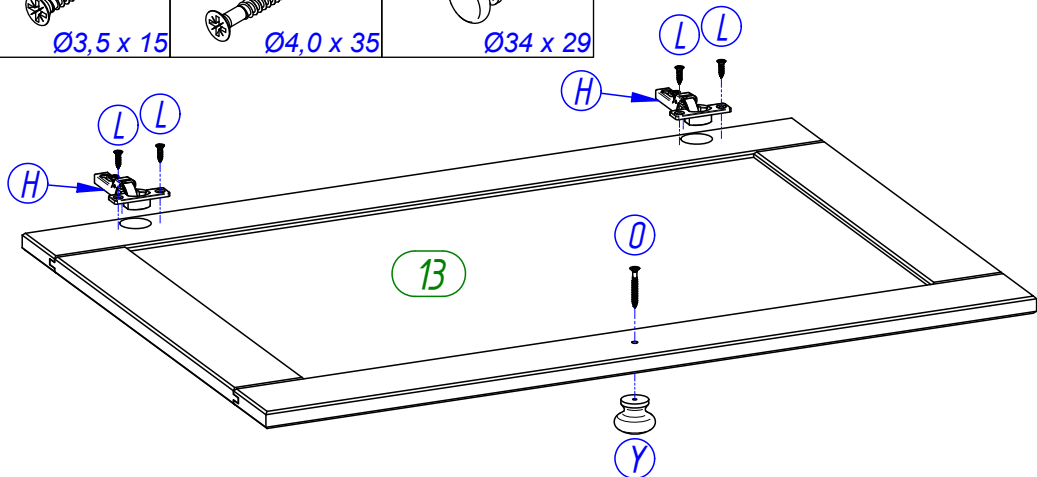

3 x2

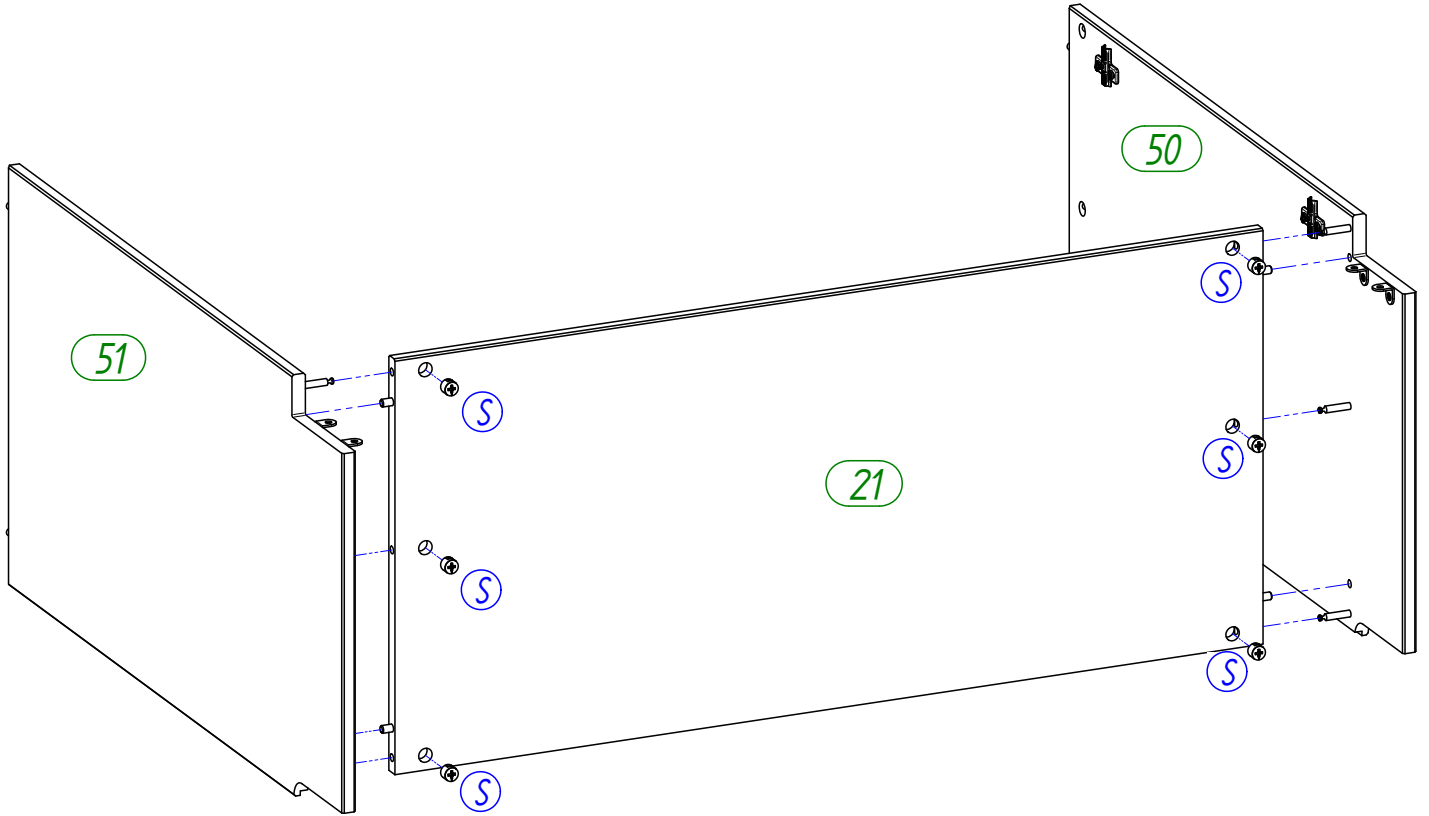
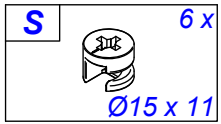

4

Achtung • Attention • Opgelet • Uwaga • Dikkat • Внимание	
(D)	Bitte montieren Sie das Spülbecken auf der Topplatte laut Aufbauanleitung des Spülbeckens als erstes.
(GB)	Please mount the basin onto the top plate first, as described in the manual.
(NL)	Plaats de bak eerst op de bovenste plaat zoals beschreven in de handleiding.
(PL)	W pierwszej kolejności zamontować zlewozmywak na górnym blacie zgodnie z instrukcją montażu zlewozmywaka.
(TR)	İlk önce, kullanım kılavuzunda tanımlandığı üzere evyenin en üst tabaka üzerinde kurulumunu gerçekleştirin.
(RU)	Сначала установите резервуар на верхнюю плиту как описано в руководстве.

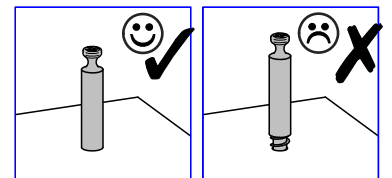
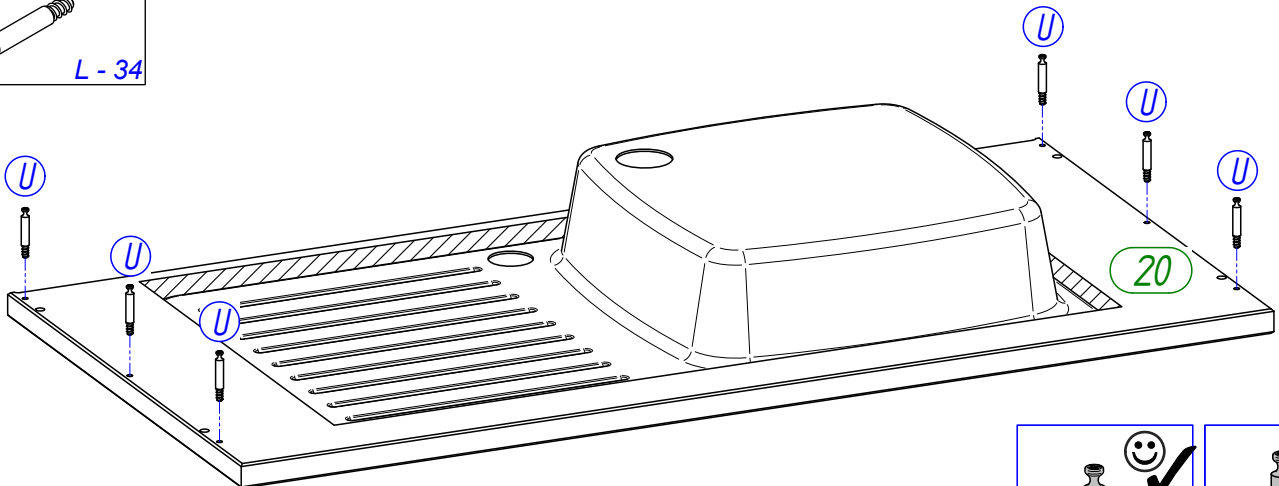
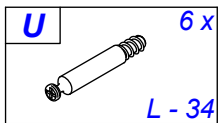

5

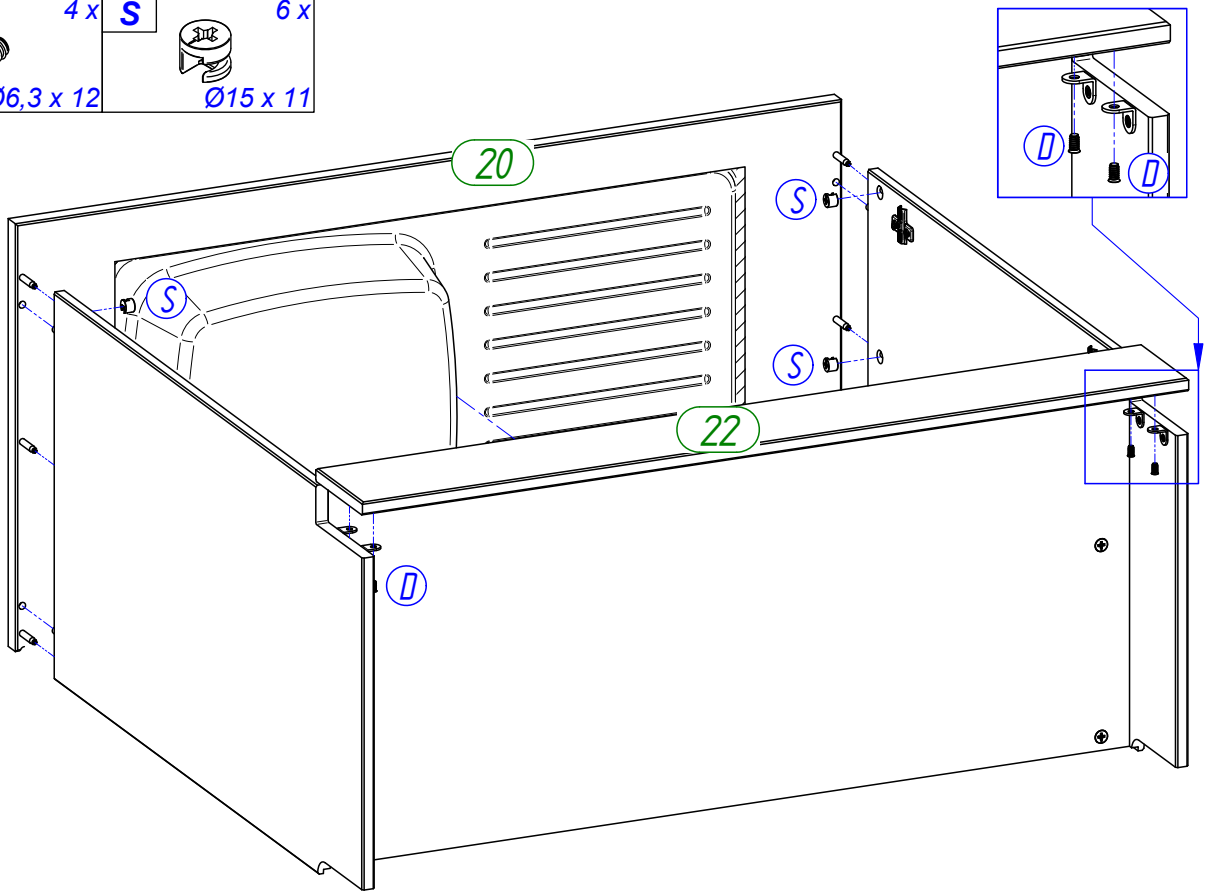
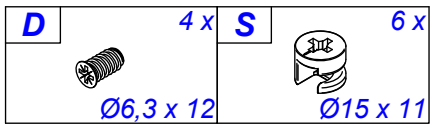

6

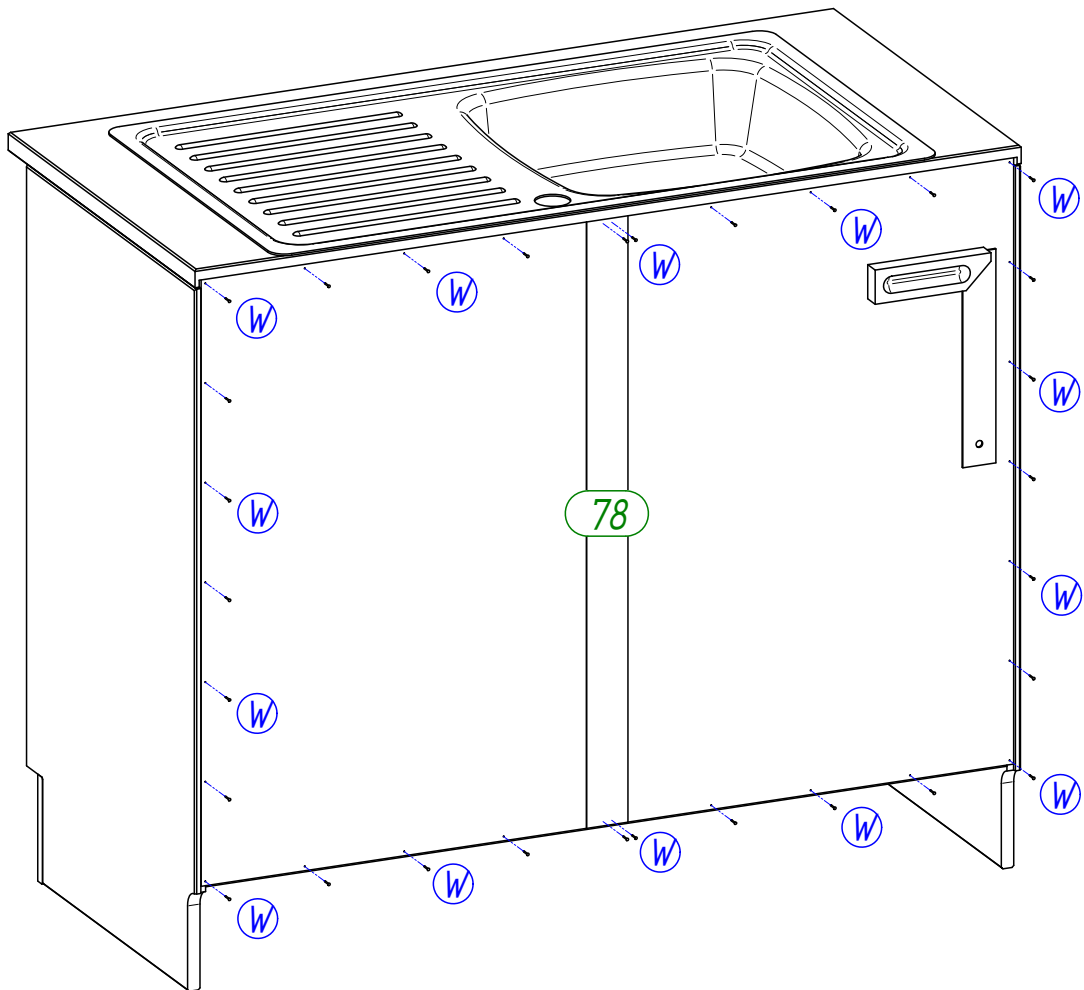
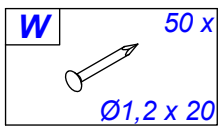

7

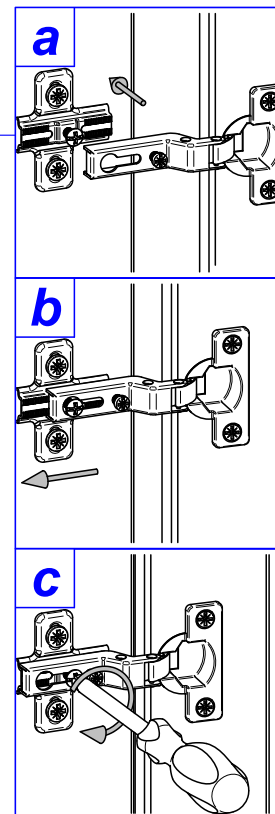
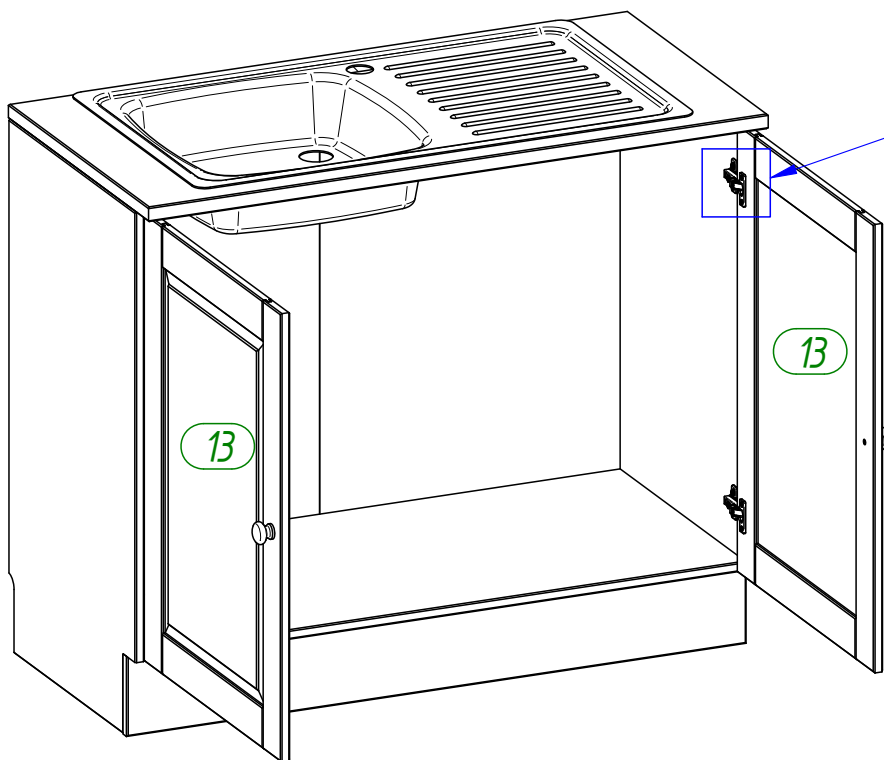

8

! Achtung • Attention • Opgelet • Uwaga • Dikkat • Внимание !

(D)	Türen einstellen (Scharniere justieren)
(GB)	Adjusting the doors (adjusting the hinges)
(NL)	Deuren instellen (scharnieren afstellen)
(PL)	Nastawić drzwi (wyrównać zawiasy)
(TR)	Kapıların ayarlanması (mentşelerin seviye ayarı)
(RU)	Регулировка дверей (регулировка шарнира)

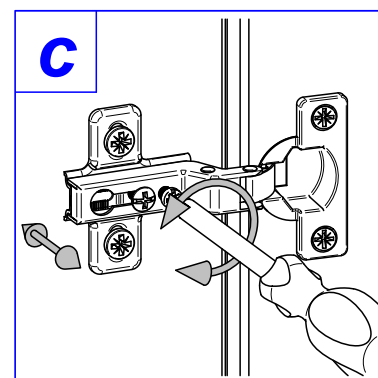
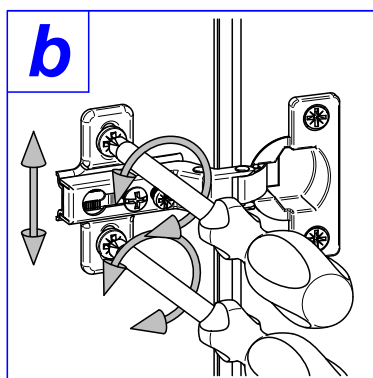
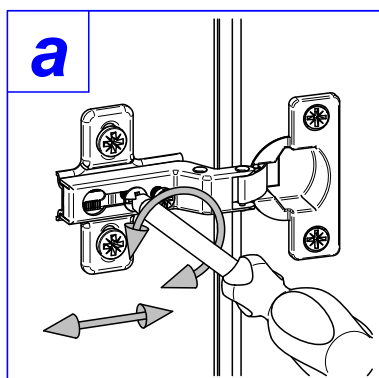
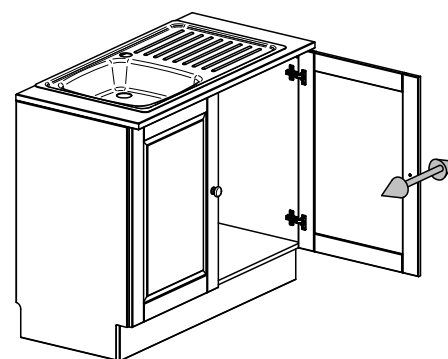
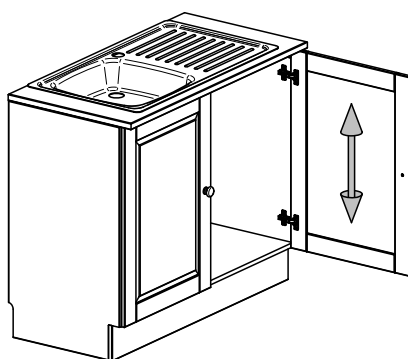
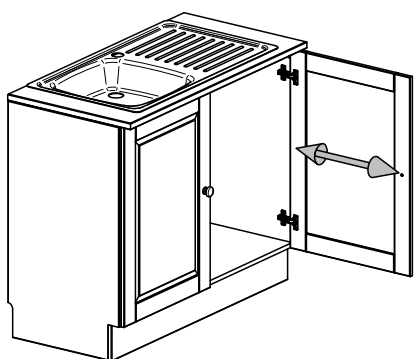

9

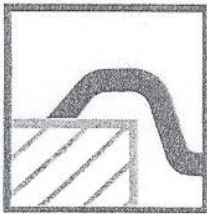

D In Ordnung
 GB OK
 TR Doğru
 RU Правильно
 NL OK
 PL PRAWIDŁOWO



D Nicht in Ordnung
 GB Not OK
 TR Yanlış
 RU Неправильно
 NL niet OK
 PL NIE PRAWIDŁOWO

NL

1. Verwijder folie
2. Plaats asfaltmat op de bak a.u.b.
3. Let er a.u.b. op dat er bij het aanbrengen van de voegband GEEN samengevoegde stukken voegband gebruikt mogen worden voor de hoeken. De verbindingsband mag niet zichtbaar zijn boven de plooi.
11. Draai opnieuw vast in deze volgorde a.u.b.

PL

1. Usunąć folię.
2. Matę bitumiczną zamontować na spodzie zlewozmywaka.
3. Należy pamiętać, by podczas montażu taśmy dylatacyjnej w rogach (zagięciach) taśma NIE była łączona z kilku części. Ponadto taśma dylatacyjna nie powinna wystawać (być widoczna) poza krawędź.
11. Napiąć w tej kolejności.

D

- 1: Folie entfernen
- 2: Bitte die Asphaltmatte auf die Unterseite des Waschbeckens montieren.
- 3: Bitte darauf achten, dass bei der Montage des Fugenbandes KEINE zusammengefügte Stücke in den Ecken verwendet werden dürfen. Die Fugenbänder dürfen auch nicht über der Kante sichtbar sein.
- 11: Bitte in dieser Reihenfolge nachspannen.

GB

1. Remove the foil
2. Please mount the asphalt mat onto the basin
3. Please note that during the fitting of the joint tape, NO assembled pieces of the joint tape are to be used for the corners. Also the joint tape should not be visible above the ridge.
11. Please retighten in this order

TR

1. Folyeyi çıkarın.
2. Asfalt keçeyi evyenin alt kısmına yerleştirin.
3. Derz bantının döşenmesi esnasında, köşe kısımlar için hazır parçaları KULLANMAYIN. Derz bandı kenarlardan görünmemelidir.
11. Lütfen bu sıra ile tekrardan gerginleştirin.

RU

1. Снимите пленку
2. Нанесите на резервуар слой битума
3. Обратите внимание на то, что при монтаже ленты для герметизации швов, смонтированные части ленты для углов НЕ используются. Лента для герметизации швов не должна также выходить за край.
11. Повторно затяните в этом порядке.

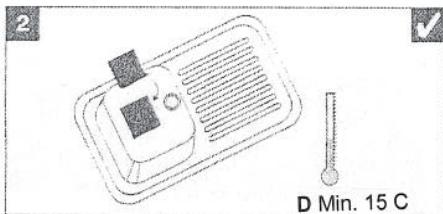
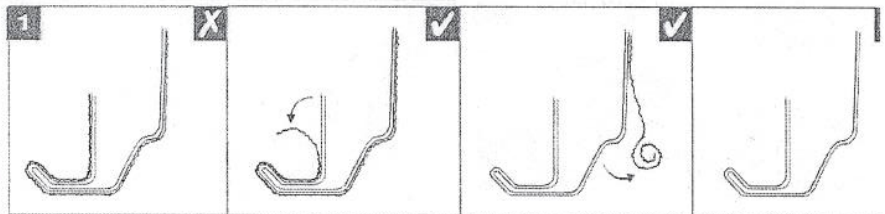

D Min. 15 C
 GB Min. 15 C
 TR Min. 15 C
 RU мин. 15 C
 NL Min. 15 C
 PL Min. 15 C

